

Deluxe Rocking Stand

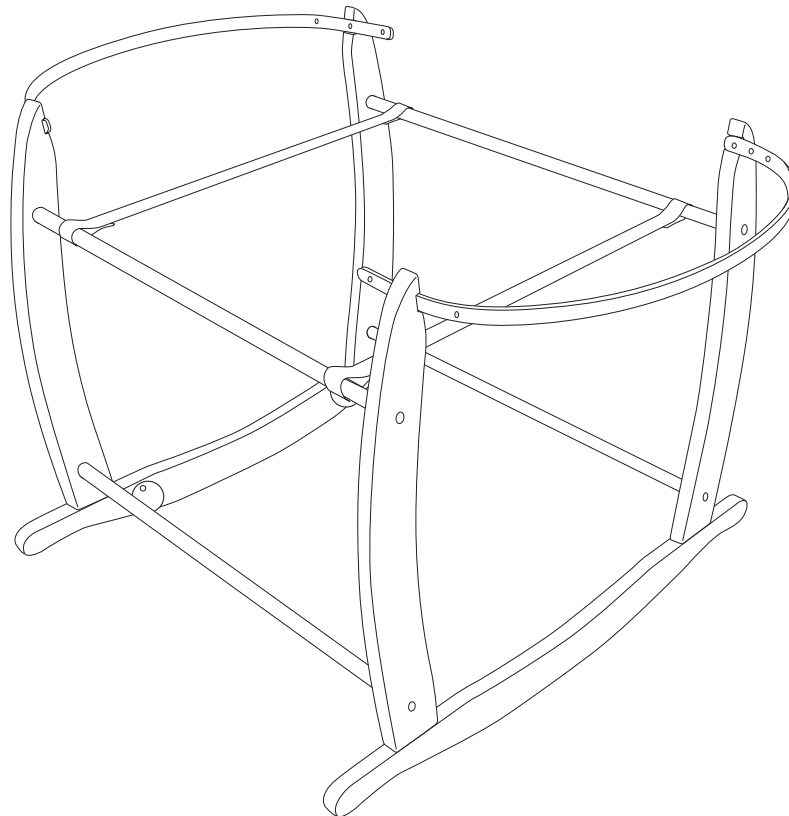

Safety

IMPORTANT - PLEASE READ INSTRUCTIONS CAREFULLY BEFORE USE AND RETAIN FOR FUTURE REFERENCE. IN ORDER THAT THE STAND YOU HAVE PURCHASED MAY BE SAFELY USED THE FOLLOWING INSTRUCTIONS MUST BE FOLLOWED.

WARNING: KEEP THE PLASTIC BAG AWAY FROM CHILDREN TO AVOID SUFFOCATION.

WARNING: This product is only suitable for a child who cannot sit up unaided

WARNING: Only use on a firm, horizontal level and dry surface

WARNING: Do not let other children play unattended near the carry cot

WARNING: Do not use if any part of the carry cot is broken, torn or missing

WARNING: Do not attach anything to the stand, which may affect its stability

Use only replacement or approved parts from Dawson Rodgers & Co Ltd.

Do not place the carry cot near an open fire or other source of strong heat

The handles and the bottom of the carry cot should be inspected regularly for signs of damage and wear

The head of the child in the carry cot should never be lower than the body of the child

If the mattress is purchased separately, it shall fit well into the product and the depth from the top of the side of the product should be less than 170mm (200mm if to be used with a stand) when the mattress is in position of use

The stand is designed for use with a palm or wicker Moses basket of min/max 700-835mm in length and 300-370mm in width.

Do not add another mattress on top of the mattress provided or recommended by Dawson Rodgers & Co Ltd

When not in use, the stand should be stored away from children.

CLEANING INSTRUCTIONS

Stand - If necessary, wipe with damp cloth

Dispose of all packaging safely before use. Complies with BS EN 1466: 2014

Dawson Rodgers & Co Ltd, Shentonfield Road, Sharston Industrial Estate Wythenshawe, Manchester, M22 4RW - 0161 491 9800 / sales@clair-de-lune.co.uk

Tools Required

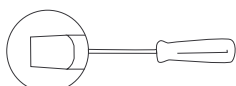

Flathead screwdriver

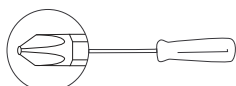

Phillips head Size 2 (PH2) screwdriver

Pozidriv®



Phillips



To prevent damaging the screws during assembly, please ensure you use the right size and type of screwdriver.

Components

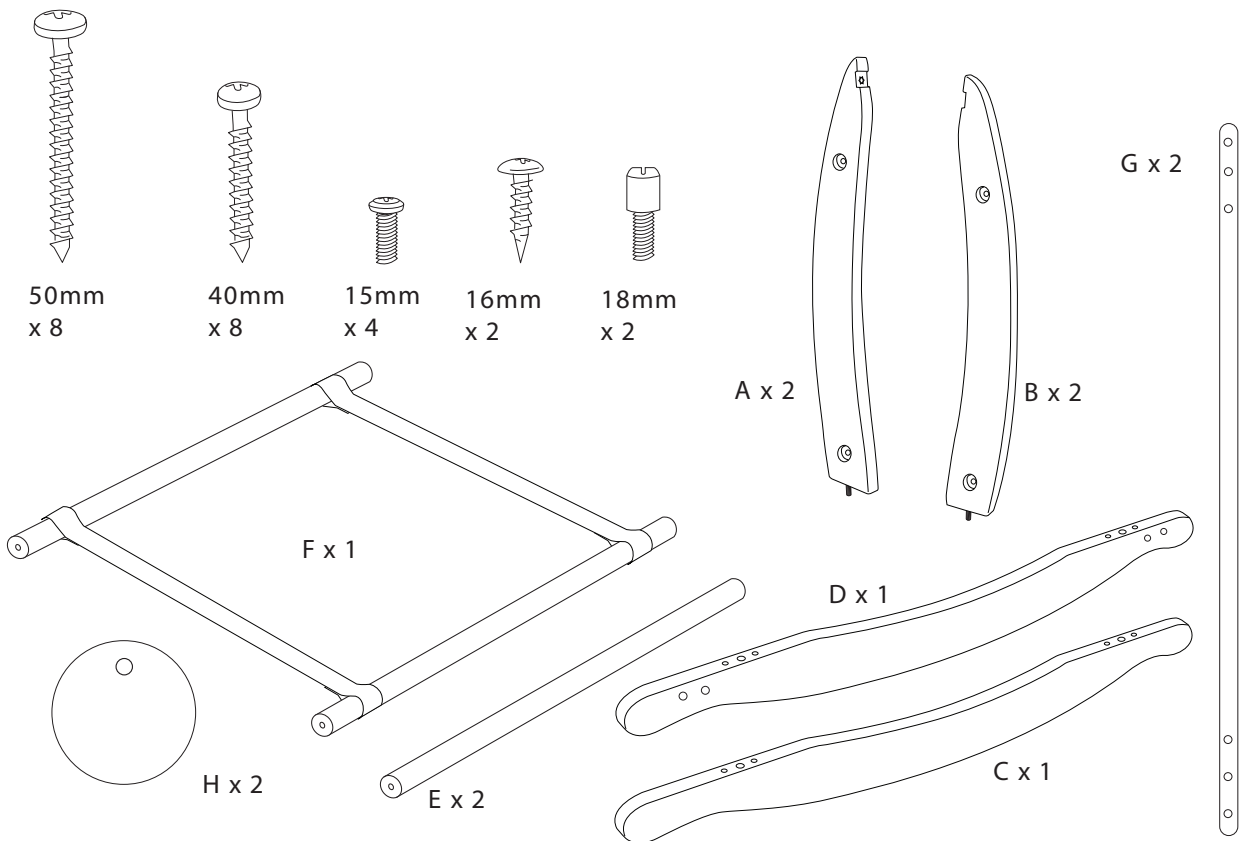

IMPORTANT: Please make sure when assembling the stand that the pre-drilled guide holes in each component are lined up and that the screws are located carefully into the holes before tightening them up.

1

Note: the uprights A and B should curve inwards towards each other with the larger recessed dowel holes facing the same way.

- Using 4 x 50mm screws, fasten 1 x A and 1 x B uprights to 1 x base rocker C through the holes in the base of C. The pre-inserted dowel in A and B will slot into the middle of the 3 holes in C.
- Repeat with the second set of parts A, B and D.

! Important: Ensure holes for stabiliser in rocker D are facing same way as recesses in uprights A and B.

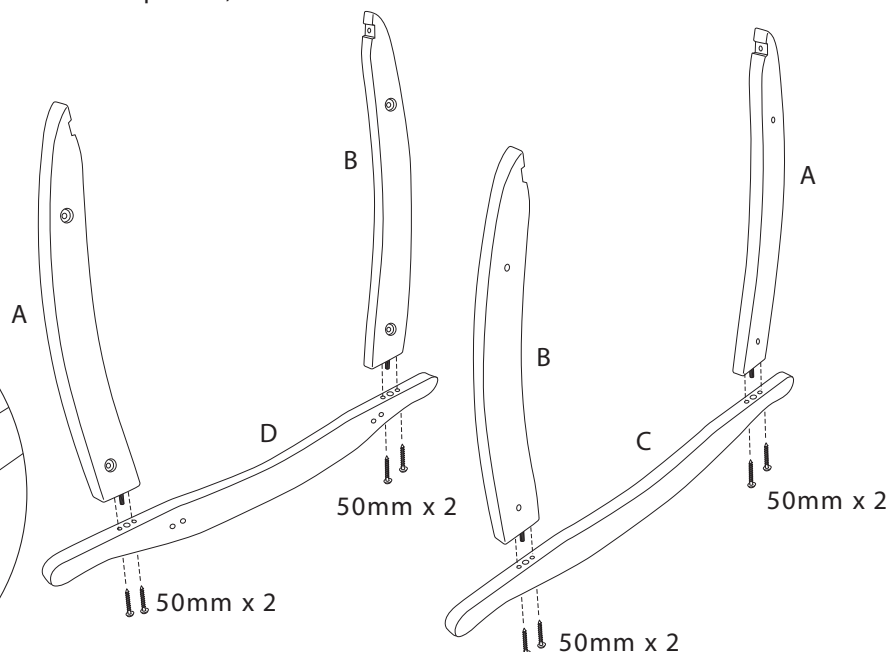
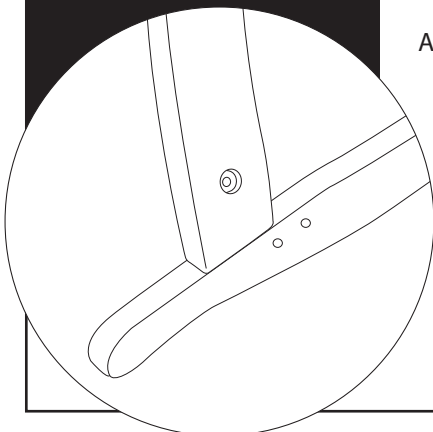

2

- Using 2 x 16mm screws, affix circular stabilisers H to inner holes at either end of D.
- Screw 2 x 18mm barrel screws to outer holes at either end of D.

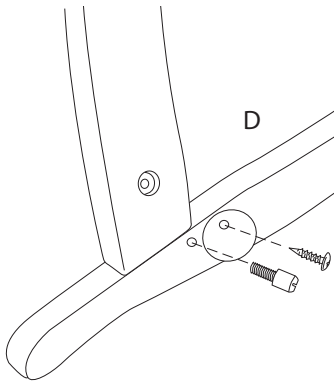

3

- Align the two sides of rocking stand so that the recesses for dowels E in the uprights face each other.
- Locate the 2 bottom dowels E into the lower recesses in uprights A/B, secure using 4 x 40mm screws.
- Locate strap & dowel assembly F into the upper recesses in uprights A/B, secure using 4 x 40mm screws.

! Important: Ensure that the staples securing straps to dowels of the strap & dowel assembly E are facing downwards.

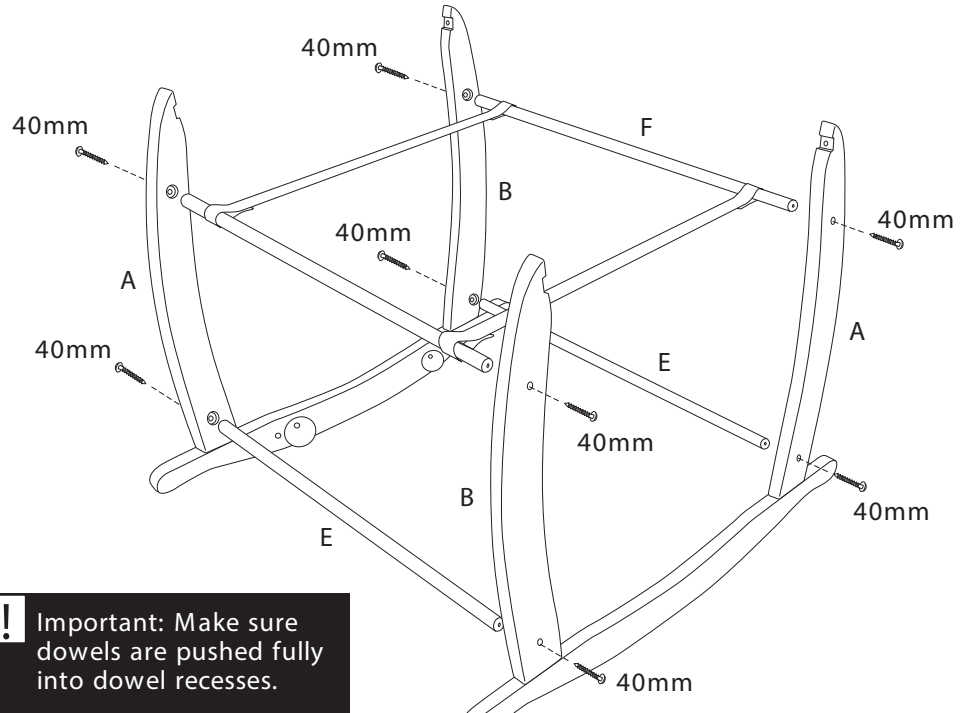

! Important: Make sure dowels are pushed fully into dowel recesses.

4

- Align the holes in the flexible straps G with the gold star-shaped fittings on the inside of the uprights A/B on both sides. Secure using 4 x 12mm screws.

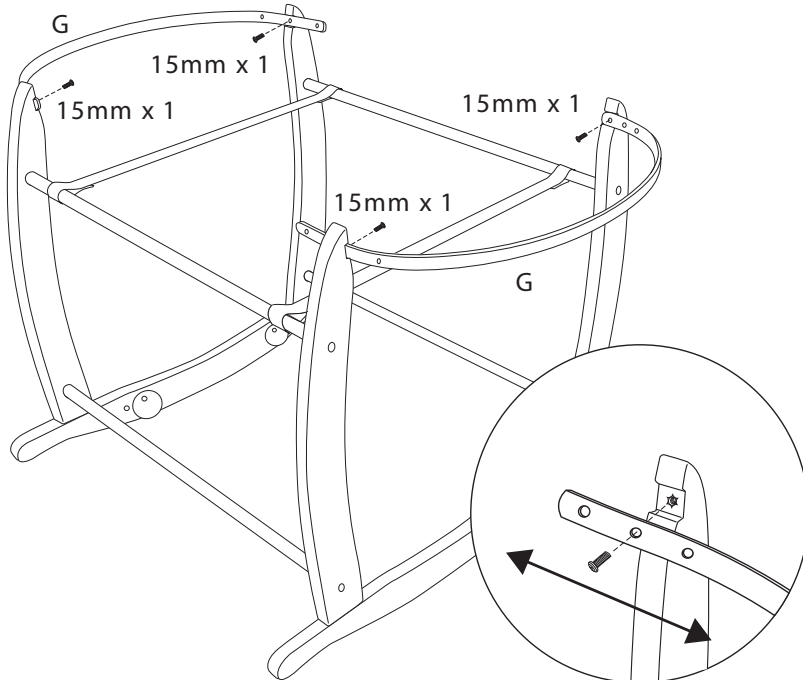

5

! Important: Stabilisers must be in locked position when stand is unattended.

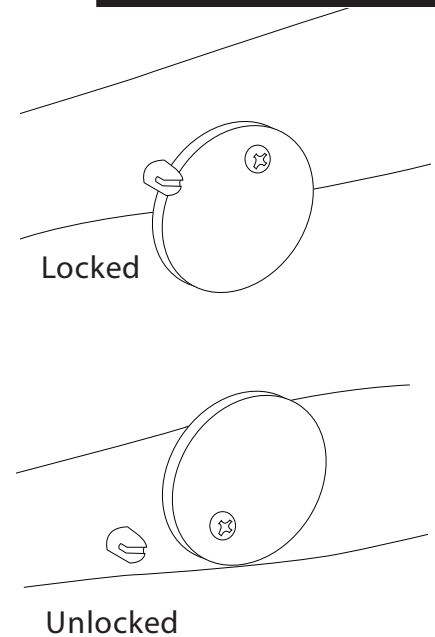

IMPORTANT: Ensure the moses basket is held securely by the end straps. Use the 3 holes on the end straps to provide adjustment. Check carefully that the moses basket is secure in the rocking stand before use.

AFTER FIRST USE PLEASE RE-CHECK TO ENSURE THAT ALL SCREWS ARE TIGHTENED SECURELY